

8 7 6 5 4 3 2 1

Parts List			
ITEM	QTY	PART NUMBER	DESCRIPTION
1	4	V20010SS	3/8-16 X 2" HHCS
2	4	V20018	3/8" LOCKWASHER
3	4	V20019	3/8" HEX NUT
4	1	V20020	2" handle Bolt
5	1	V20021	Handle Washer
6	1	V20060	VALVE STEM THRUST BEARING
7	1	V25214V	#44 O-RING, FKM
8	1	VFT25254	2" FP FEMALE NPT STUBBY BODY
9	1	VS20151	VALVE STEM W/ BEARING
10	1	VS25153	2" FP STUBBY HANDLE
11	1	VS25255	2" Stubby Full Port Ball
12	2	VS25258AR1	3" FP Ball Seat
13	1	VS25356	2" FP STUBBY ENDPLATE

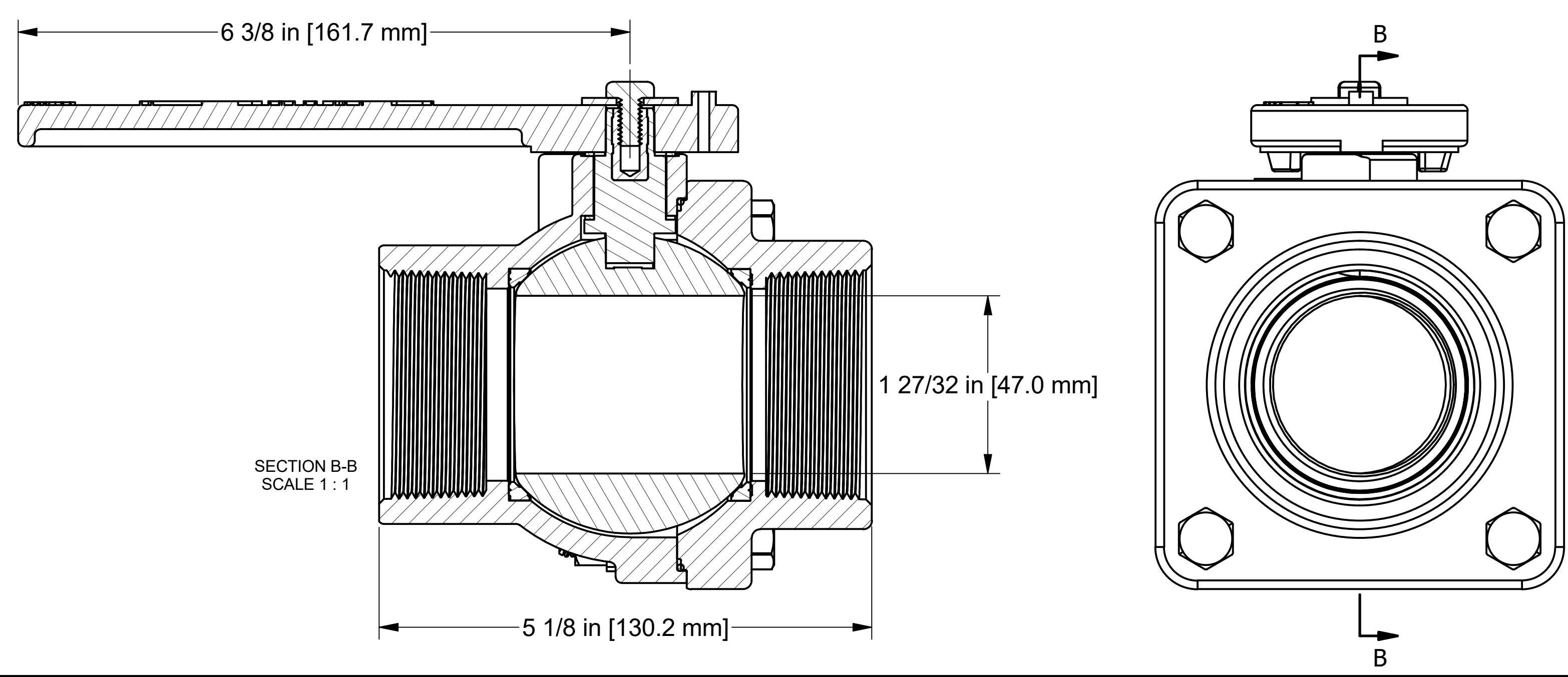
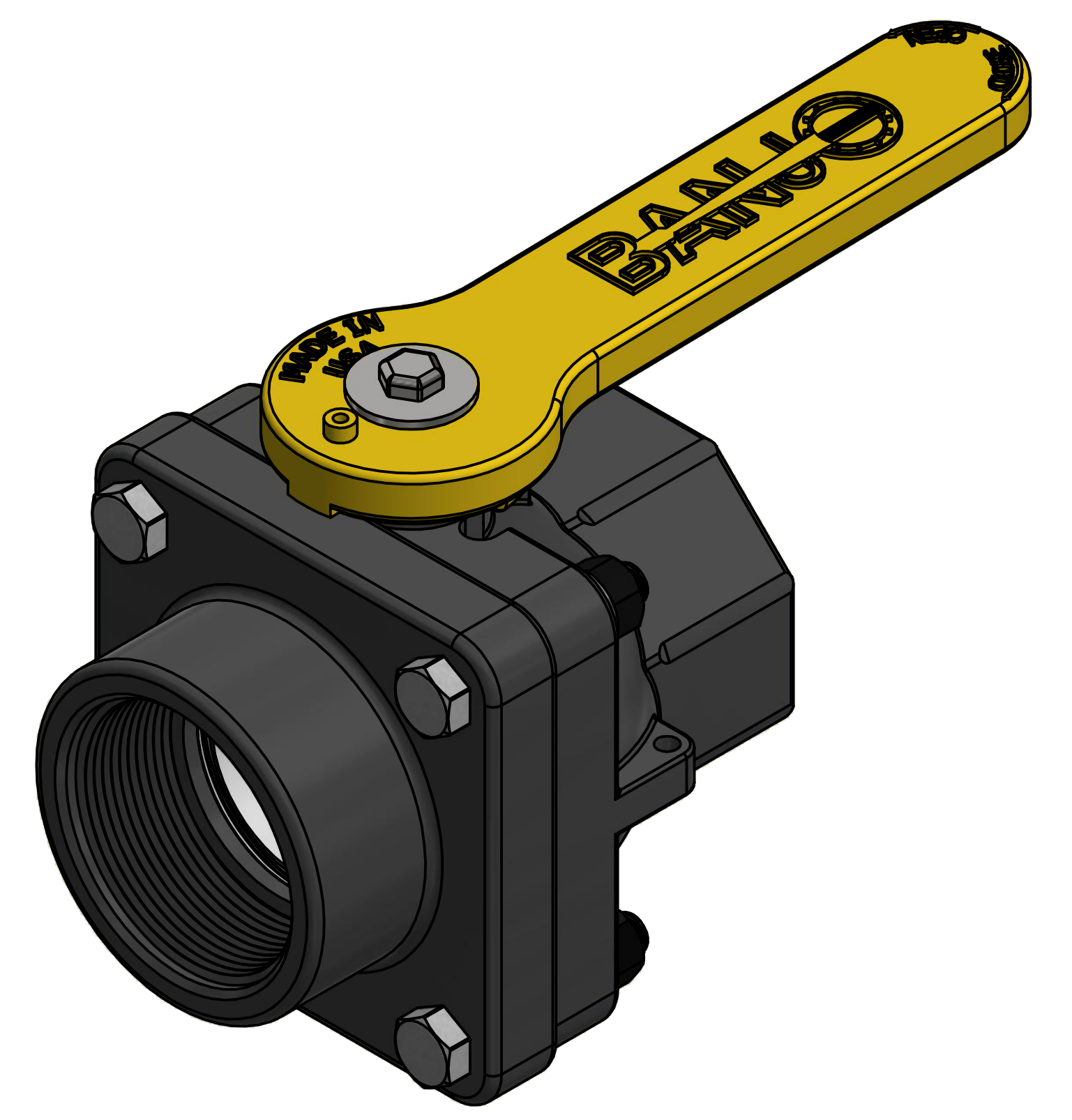
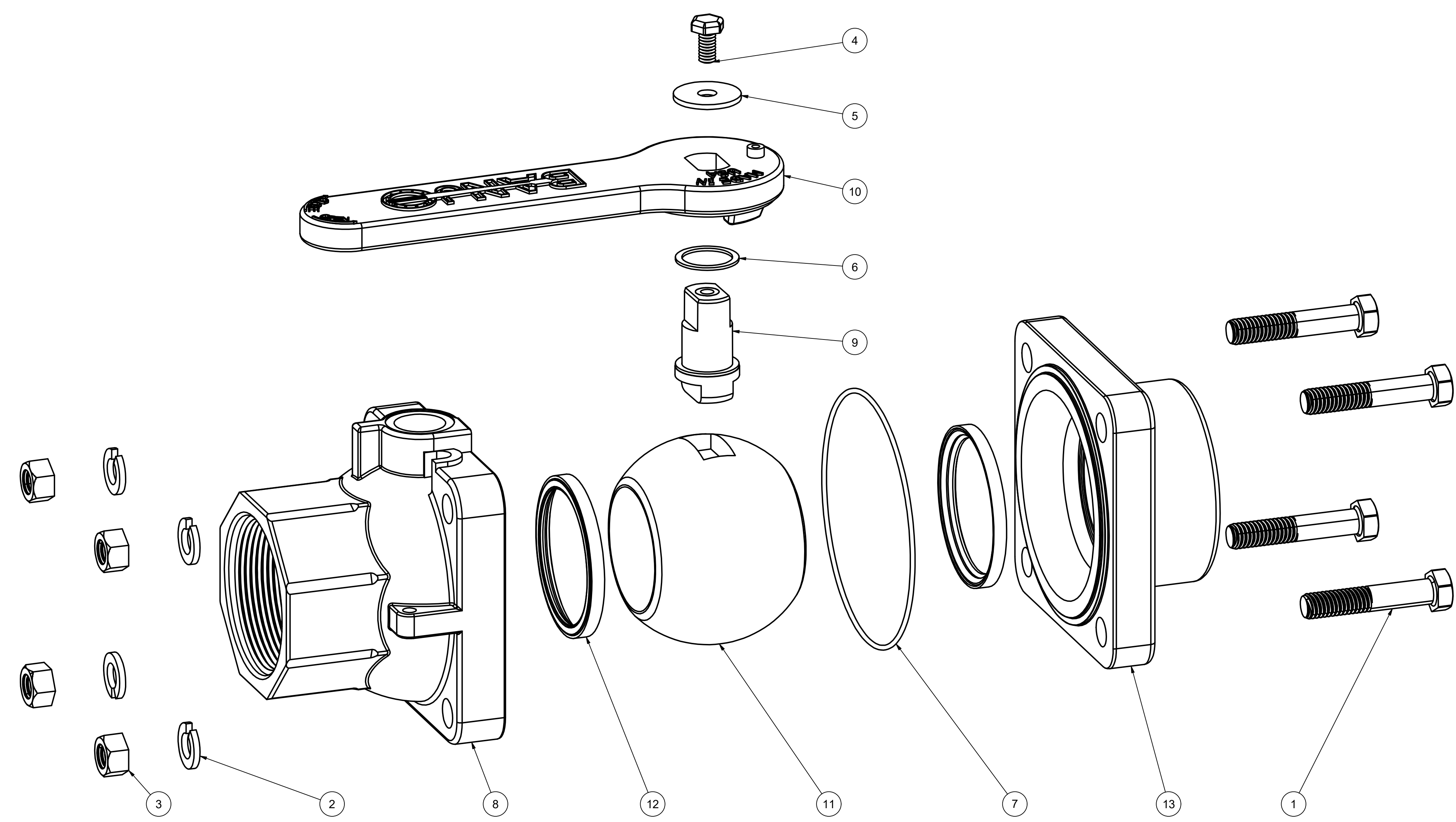

THIS DRAWING AND ALL INFORMATION CONTAINED THEREON ARE THE EXCLUSIVE PROPERTY OF BANJO CORPORATION.

UNLESS SPECIFICALLY NOTED, THIS DRAWING AND ITEMS SHOWN ON THIS DRAWING ARE SUBJECT TO CHANGE AT ANY TIME.

BANJO CORPORATION 150 BANJO DRIVE, CRAWFORDSVILLE, IN 47933 WEB SITE: WWW.BANJO.CORP.COM E-MAIL: BANJOSALES@IDEXCORP.COM	
DESCRIPTION	2" FP FPT x FPT Stubby Valve
PART NUMBER	VS204FP

8 7 6 5 4 3 2 1