

SECTION A-A
SCALE 3/5

PARTS LIST			
ITEM	QTY	PART NUMBER	DESCRIPTION
1	6	V20018	3/8" LOCKWASHER
2	6	V20019	3/8" HEX NUT
3	1	V25020	3/8" HANDLE BOLT
4	1	V25060	VALVE STEM THRUST BEARING
5	1	V25121	3/8" FENDER WASHER
6	1	V25153	2" FP HANDLE
7	1	V25160	STEM BUSHING
8	1	V25163	AS568A -214 O-RING, FKM, BROWN
9	1	V30151	STEM 3"FP STUBBY, MACHINED
10	6	V35017	3/8"-16 x 6" HHCS, 18-8SS
11	1	V35254	3" FP VALVE BODY
12	1	V35255A	3" FULL PORT BALL, TUMBLED
13	2	V35258A	3" FP BALL SEAT
14	2	V35264	3" NPT FP ENDPLATE, MACHINED
15	2	V35265	3" FP BODY O-RING FKM
16	1	VL1016	200 PSI PRESSURE LABELS FKM (N/S)

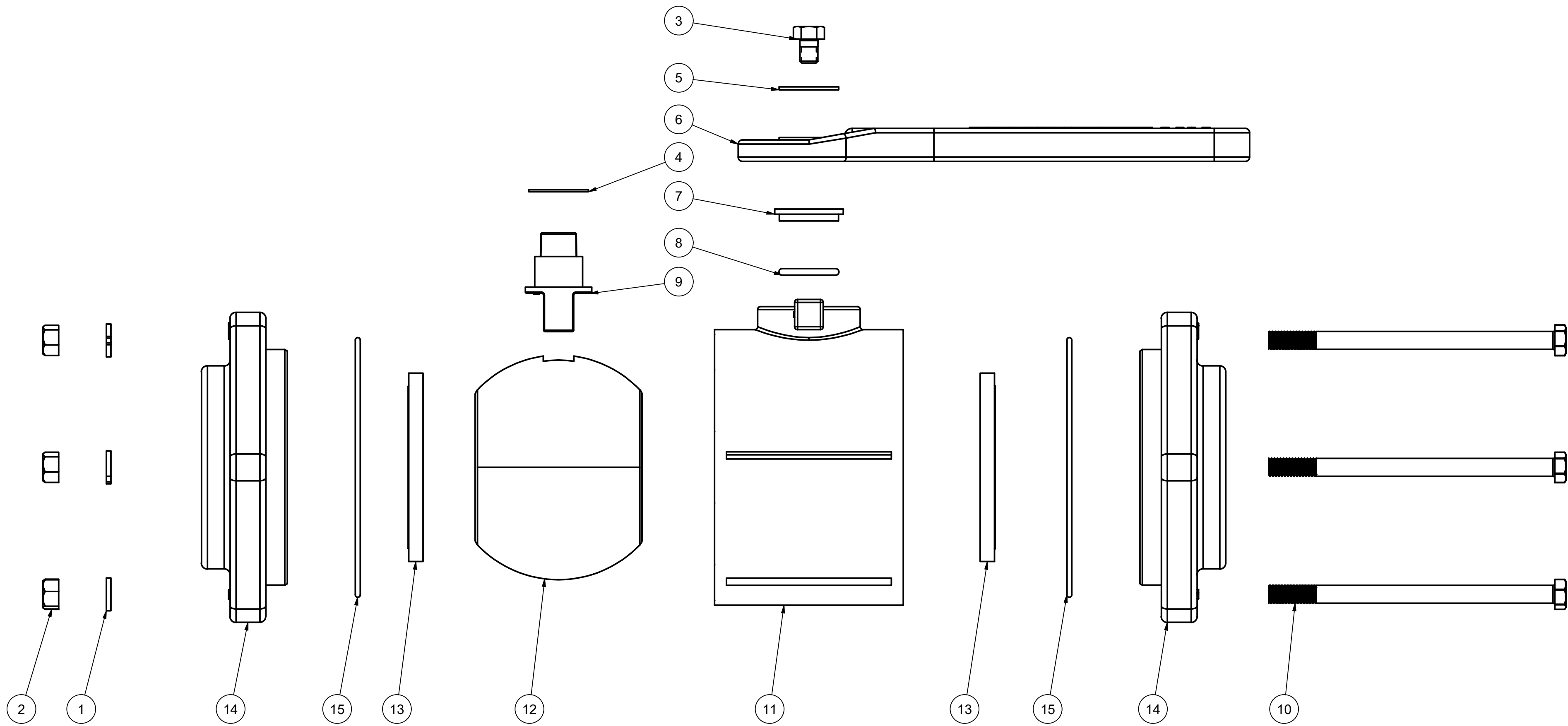

THIS DRAWING AND ALL INFORMATION CONTAINED THEREON ARE THE EXCLUSIVE PROPERTY OF BANJO CORPORATION.
UNLESS SPECIFICALLY NOTED, THIS DRAWING AND ITEMS SHOWN ON THIS DRAWING ARE SUBJECT TO CHANGE AT ANY TIME.

BANJO CORPORATION
150 BANJO DRIVE, CRAWFORDSVILLE, IN 47933
WEB SITE: WWW.BANJO.CORP.COM
E-MAIL: BANJOSALES@IDEXCORP.COM

DESCRIPTION
3" FPT POLY FP VALVE

PART NUMBER
V300FP