

PARTS LIST

ITEM	QTY	PART NUMBER	DESCRIPTION
1	1	V25020	3/8" HANDLE BOLT
2	1	V25160	STEM BUSHING
3	1	V25163	AS568A -214 O-RING, FKM, BROWN
4	6	V20019	3/8" HEX NUT
5	6	V20018	3/8" LOCKWASHER
6	1	V25151B	STEM 2"FP & 3"FP, MACHINED
7	2	V30265	AS568A -156 O-RING, FKM, BROWN
8	1	V25060	VALVE STEM THRUST BEARING
9	2	V30258A	3" FP BALL SEAT
10	1	V25121	3/8" FENDER WASHER
11	1	V25153	2" FP HANDLE
12	6	V30017	3/8" - 16 X 5" SS BODY BOLT
13	1	V30254	3" STD PORT VALVE BODY
14	2	V30264	3" NPT STD PORT ENDPLATE, MACHINED
15	1	V30255	3" VALVE BALL, TUMBLED
16	1	VL1017	225 PSI PRESSURE LABEL FKM (N/S)

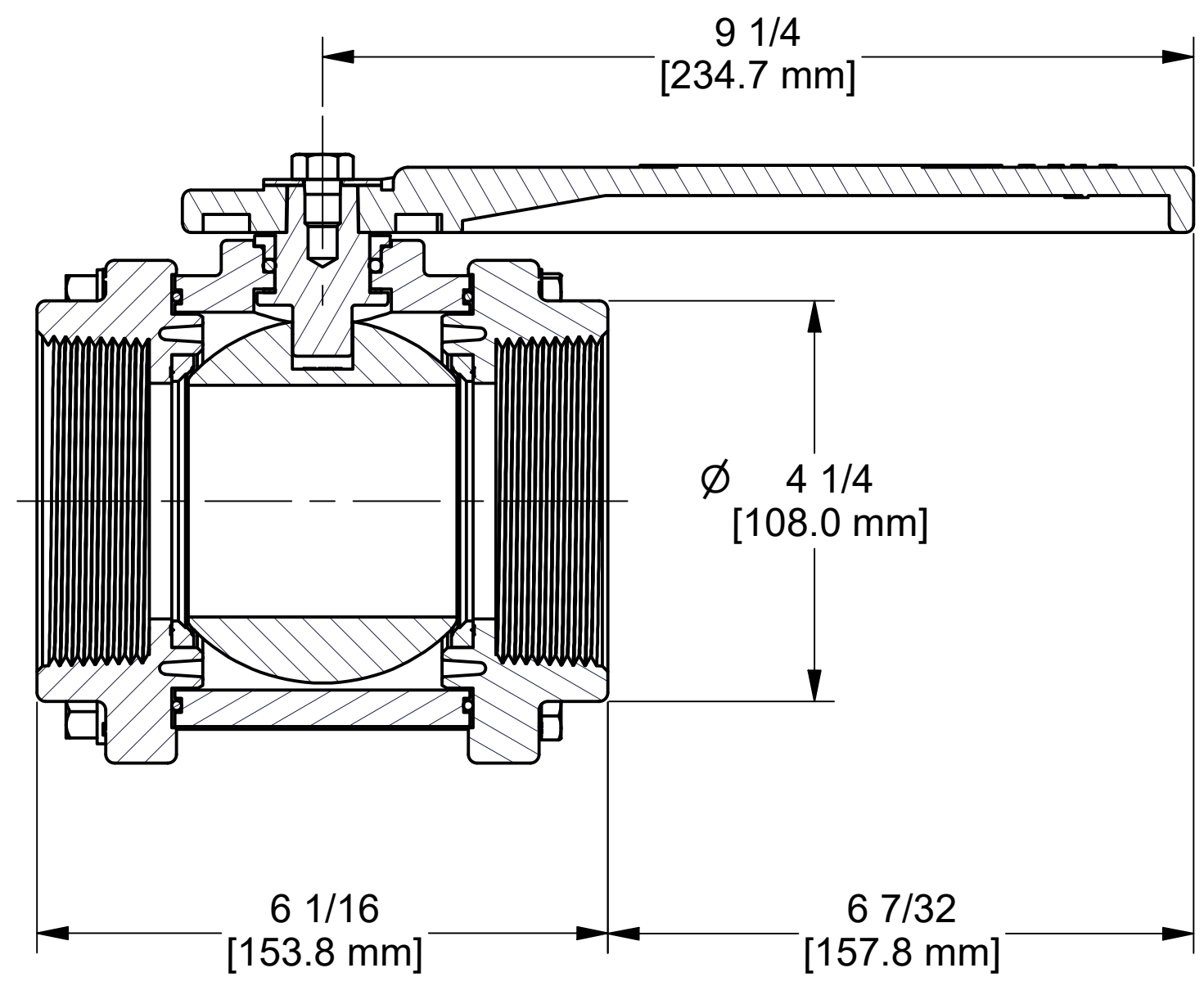

SECTION A-A  
SCALE 3/5

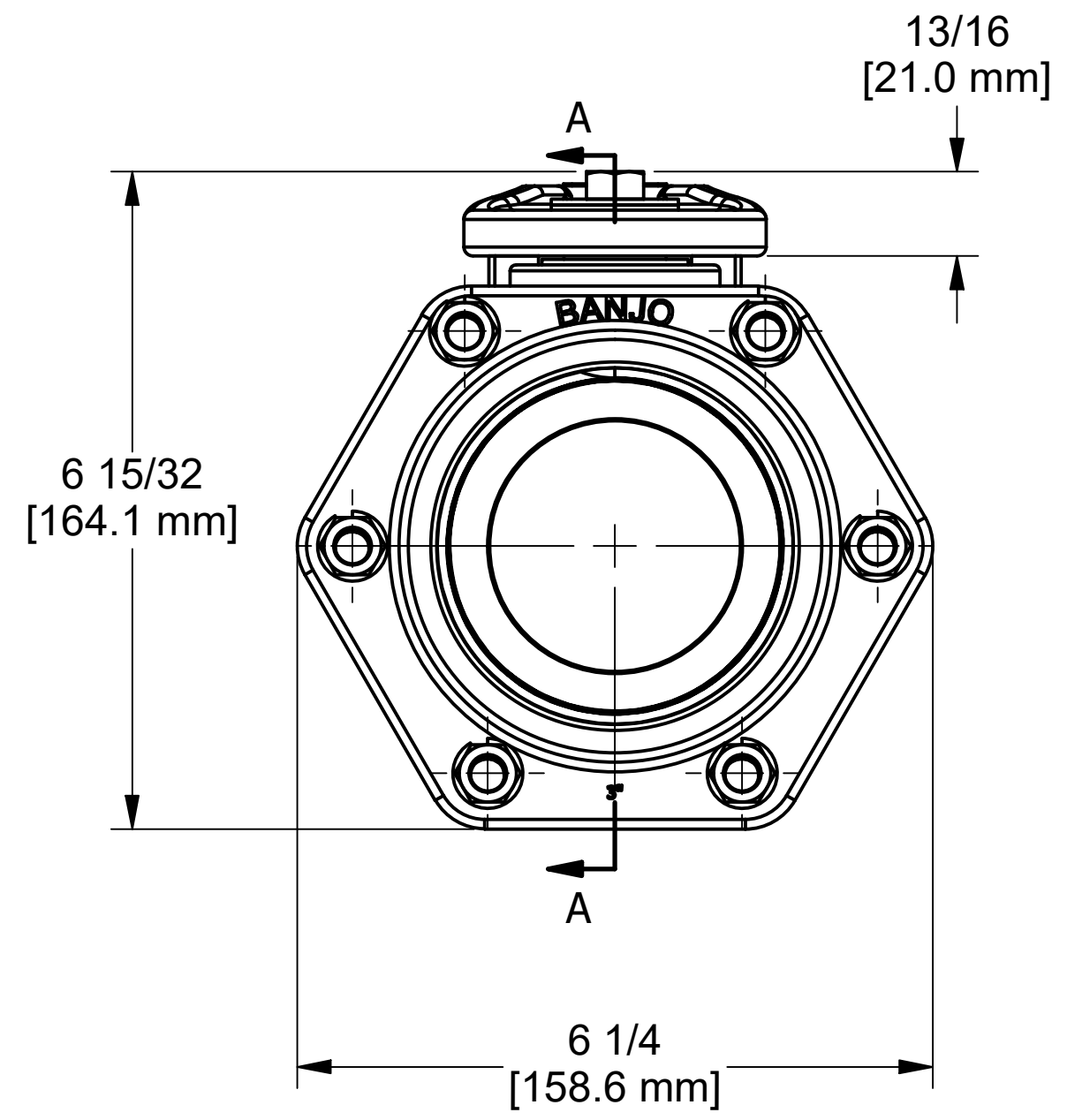
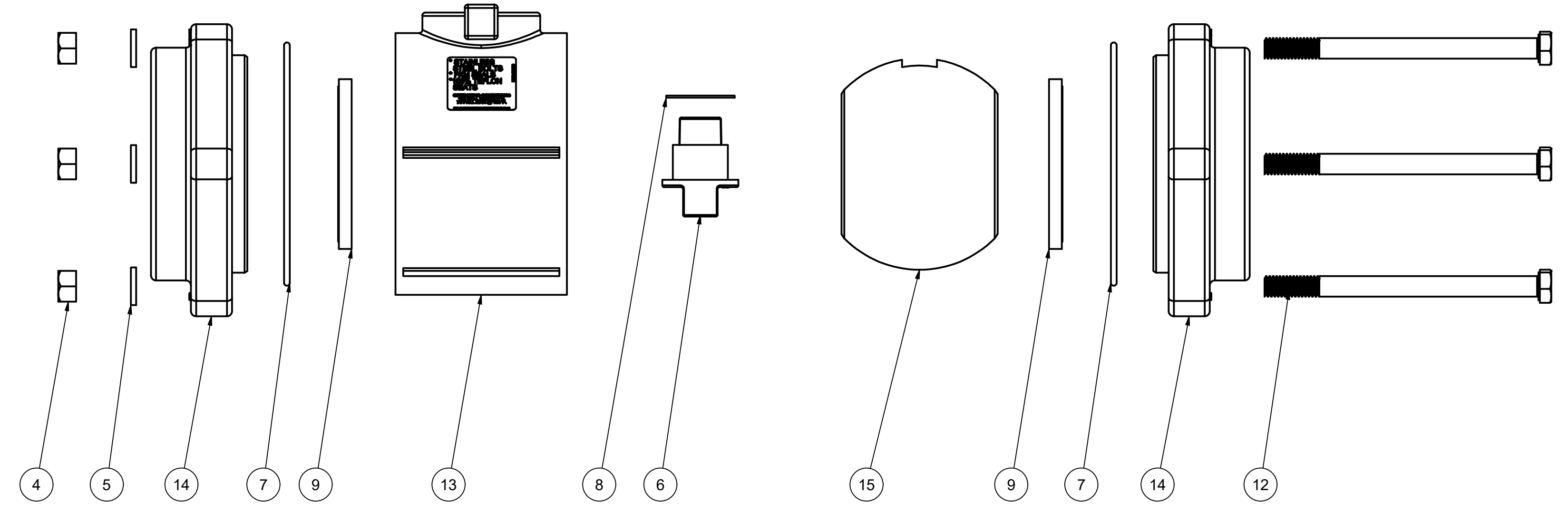
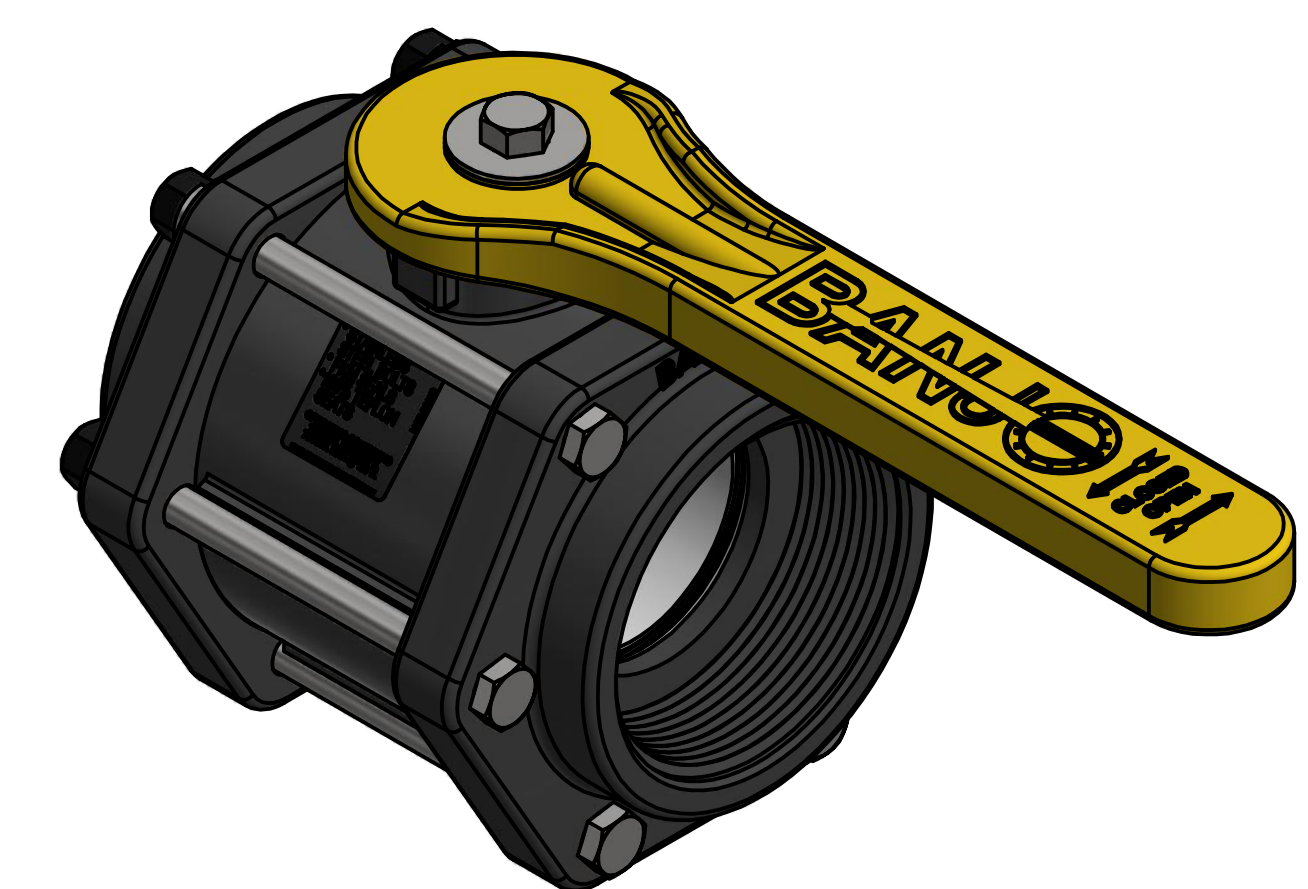
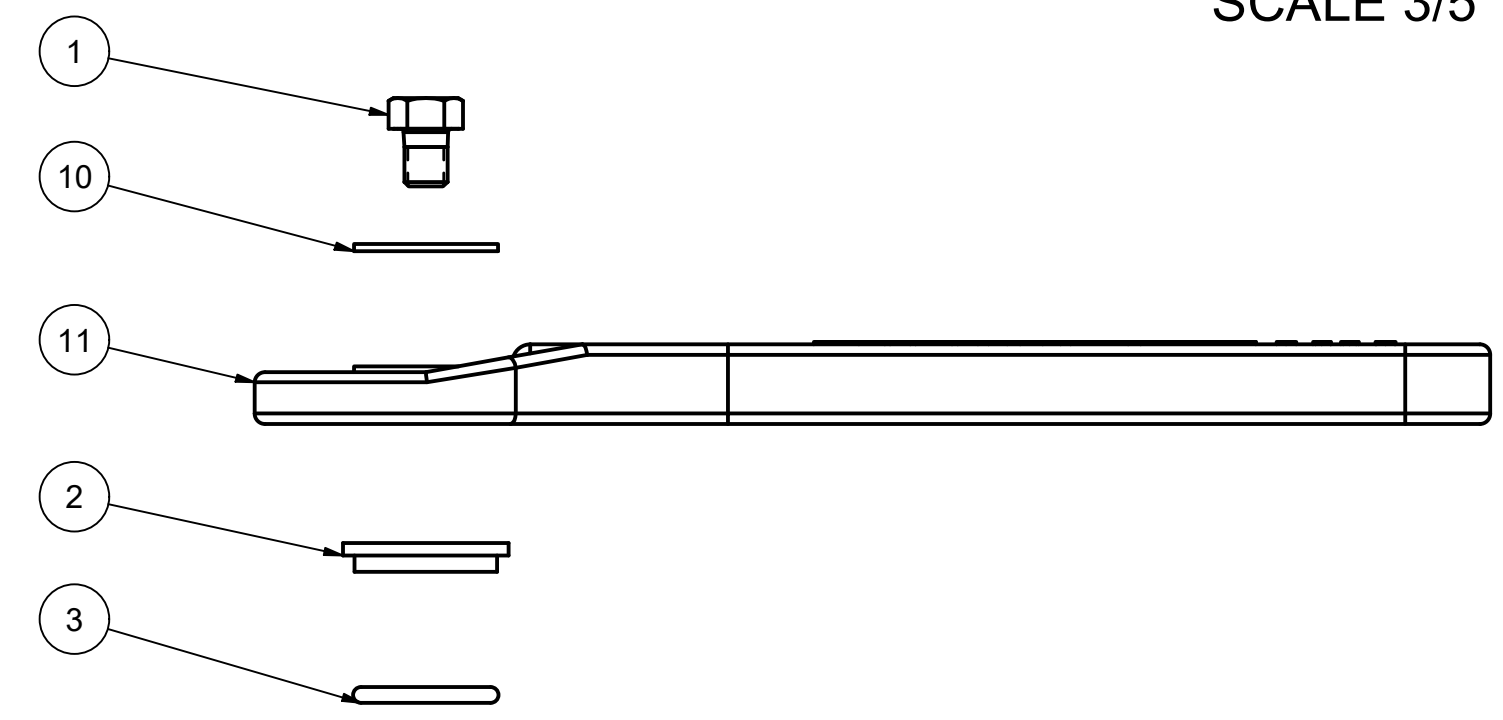

THIS DRAWING AND ALL INFORMATION CONTAINED THEREON ARE THE EXCLUSIVE PROPERTY OF BANJO CORPORATION.  
UNLESS SPECIFICALLY NOTED, THIS DRAWING AND ITEMS SHOWN ON THIS DRAWING ARE SUBJECT TO CHANGE AT ANY TIME.

BANJO CORPORATION  
150 BANJO DRIVE, CRAWFORDSVILLE, IN 47933  
WEB SITE: WWW.BANJO.CORP.COM  
E-MAIL: BANJOSALES@IDEXCORP.COM  
DESCRIPTION  
**3" BALL VALVE ASSEMBLY**  
PART NUMBER  
**V300**