

Parts List			
ITEM	QTY	PART NUMBER	DESCRIPTION
1	4	V20017	3/8-16 X 4" HHCS
2	4	V20018	3/8" LOCKWASHER
3	4	V20019	3/8" HEX NUT
4	1	V20020	2" handle Bolt
5	1	V20021	Handle Washer
6	1	V20151M	VALVE STEM W/ BEARING
7	1	V20153	HANDLE
8	1	V20159	2" STEM BUSHING
9	1	V20163	#116 O'RING, FKM
10	1	V20254	2" VALVE BODY
11	1	V20255A	2" Valve Ball
12	2	V20257	1 1/2" FNPT END PLATE
13	2	V20258A	2" Valve Seat
14	2	V20264	#151 O'RING, FKM
15	1	VL1001	150 PSI Pressure Label Viton Seals

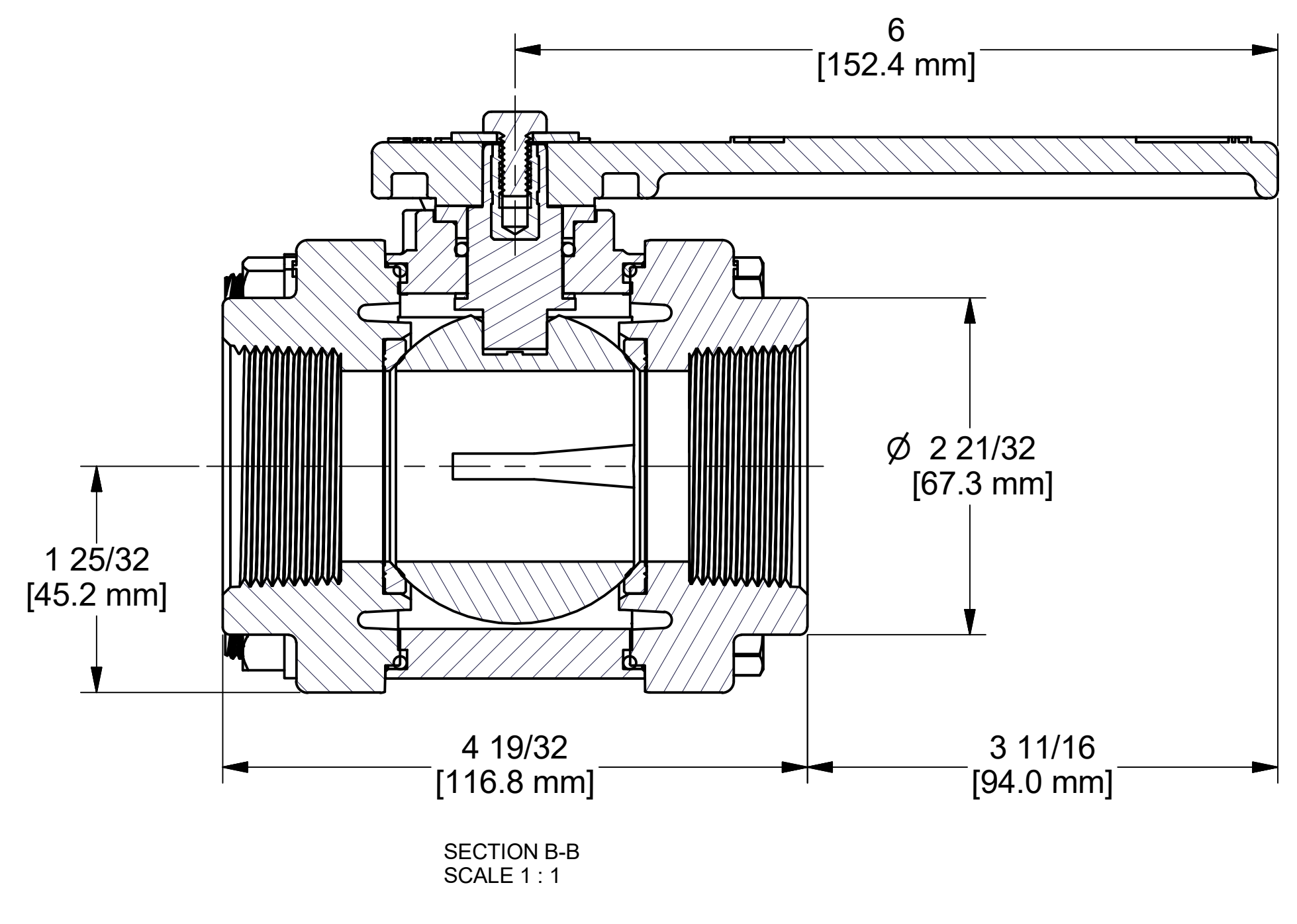
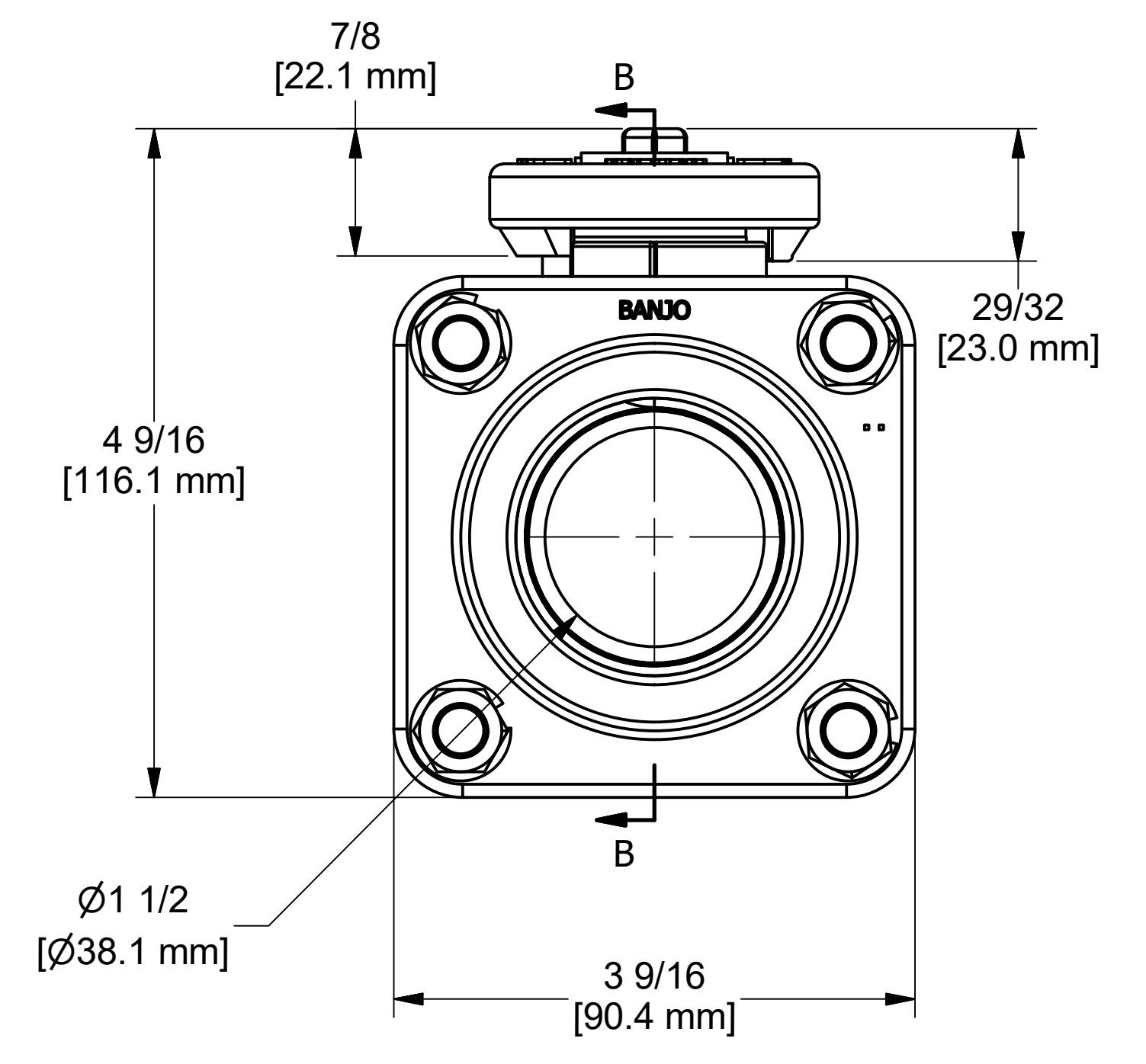
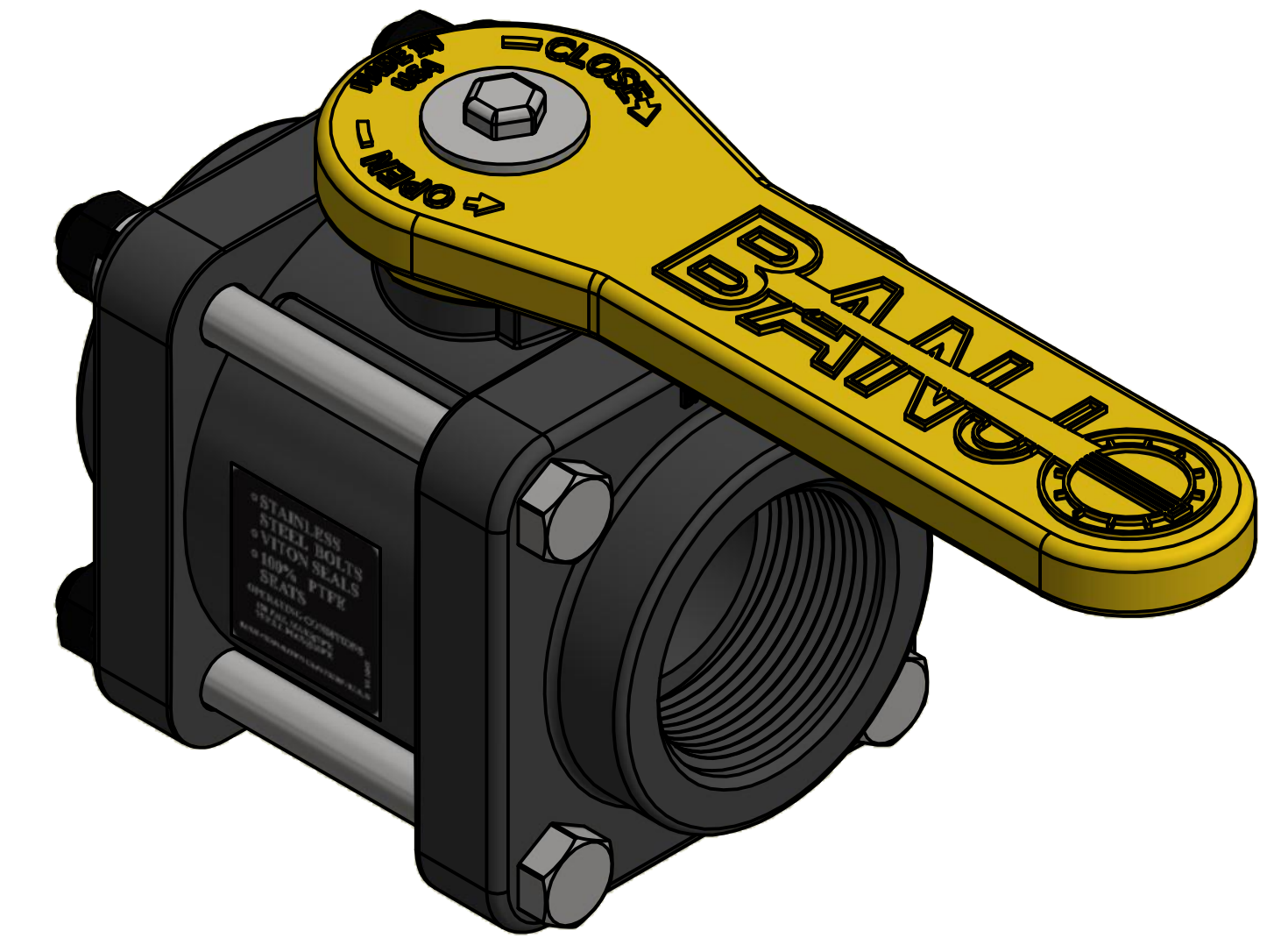

THIS DRAWING AND ALL INFORMATION CONTAINED THEREON ARE THE EXCLUSIVE PROPERTY OF BANJO CORPORATION.
UNLESS SPECIFICALLY NOTED, THIS DRAWING AND ITEMS SHOWN ON THIS DRAWING ARE SUBJECT TO CHANGE AT ANY TIME.

BANJO CORPORATION
150 BANJO DRIVE, CRAWFORDSVILLE, IN 47933
WEB SITE: WWW.BANJO.CORP.COM
E-MAIL: BANJOSALES@DEXCORP.COM

DESCRIPTION	1 1/2" VALVE ASSEMBLY
PART NUMBER	V150