

PARTS LIST			
ITEM	QTY	PART NUMBER	DESCRIPTION
1	1	050DECAL	DECAL (N/S)
2	4	V20017	3/8-16 X 4" HHCS
3	4	V20018	3/8" LOCKWASHER
4	4	V20019	3/8" HEX NUT
5	1	V20020	2" HANDLE BOLT
6	1	V20021	HANDLE WASHER
7	1	V20151M	VALVE STEM W/ BEARING
8	1	V20159	2" STEM BUSHING
9	1	V20163	AS568A -116 O-RING, FKM, BROWN
10	2	V20264	AS568A -151 O-RING, FKM, BROWN
11	2	V20267	1 1/4" NPT ENDPLATE, MACHINED
12	1	V20344S	1 1/4" NPT SL VALVE BODY, MACHINED
13	1	V20353C	1 1/8" CAPLUG
14	1	V20353TS	2" SIDE LOAD T-HANDLE
15	1	V20355S	2" 3-WAY SL BALL, TUMBLED
16	2	VE20258A	2" VE SEAT TFM
17	1	VL1018	300 PSI DECAL LABEL FKM SEALS (N/S)

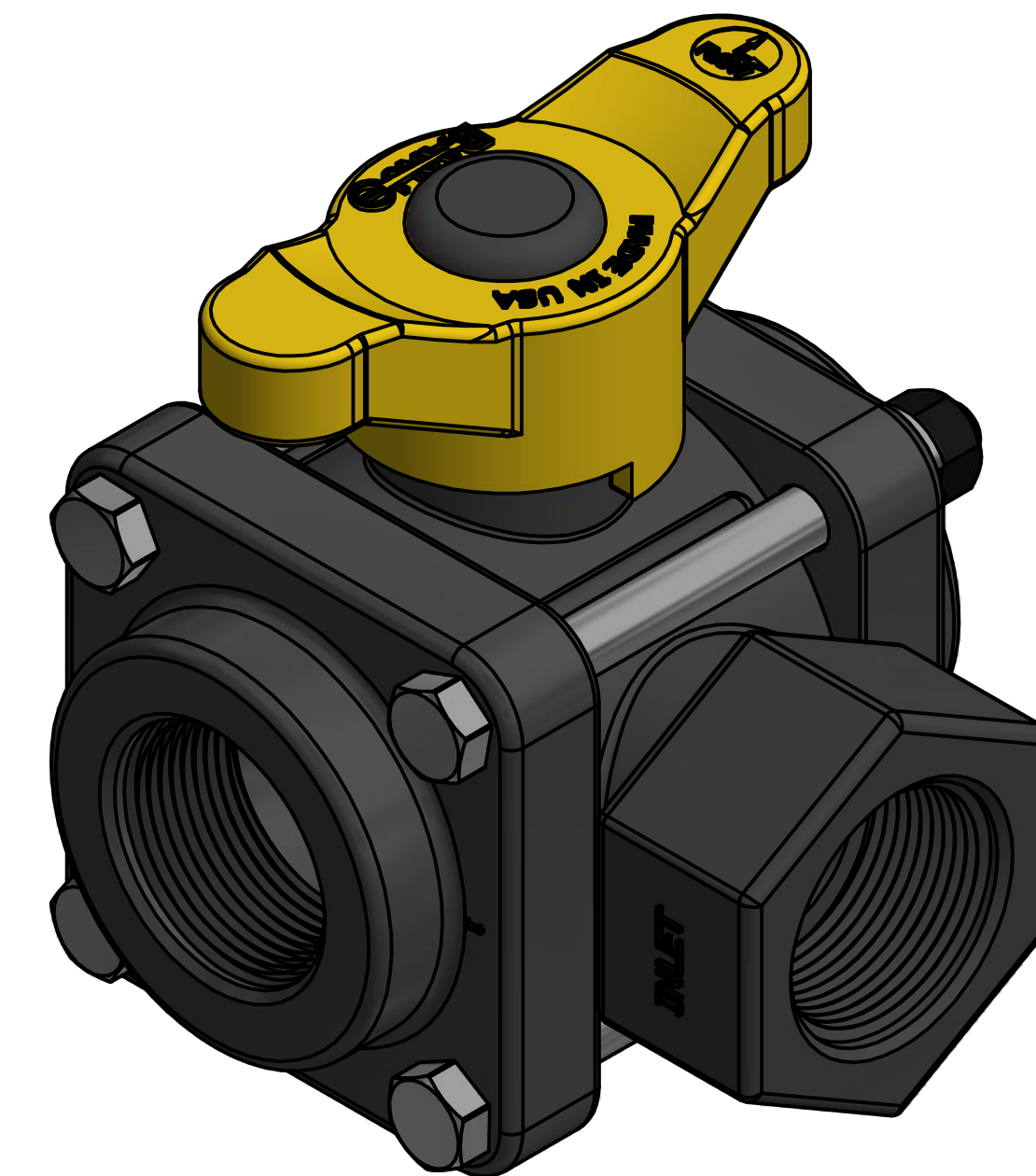
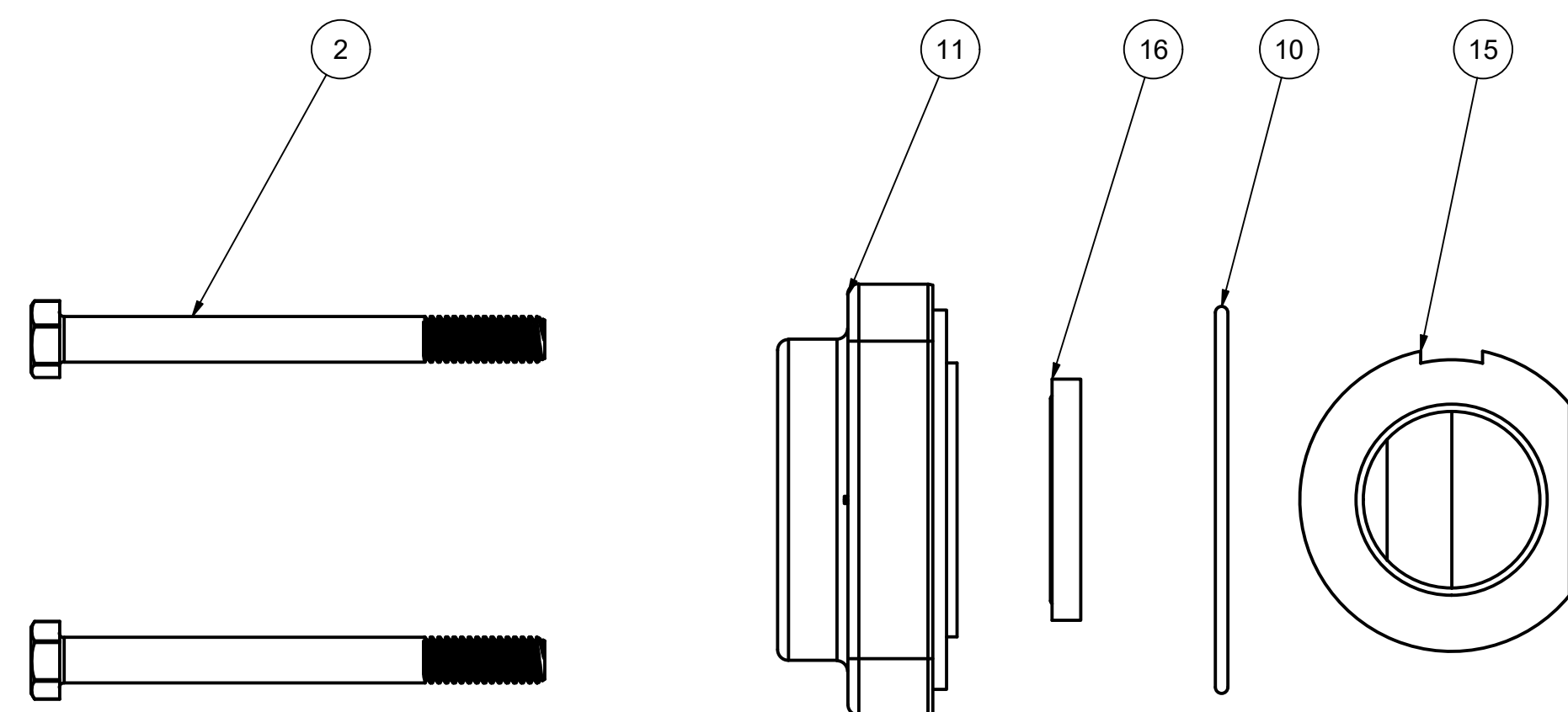
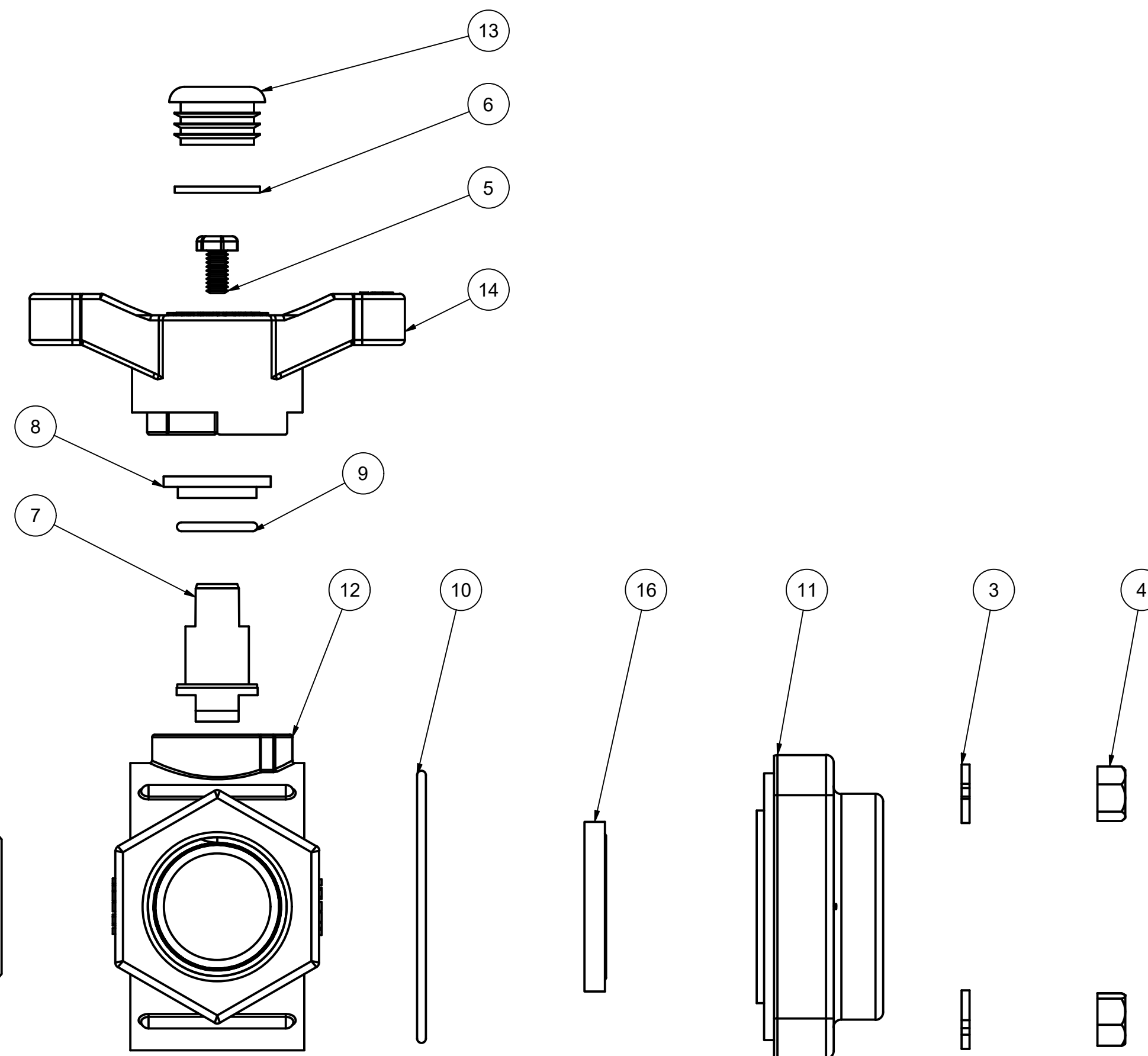

THIS DRAWING AND ALL INFORMATION CONTAINED THEREON ARE THE EXCLUSIVE PROPERTY OF BANJO CORPORATION.

UNLESS SPECIFICALLY NOTED, THIS DRAWING AND ITEMS SHOWN ON THIS DRAWING ARE SUBJECT TO CHANGE AT ANY TIME.

BANJO CORPORATION
 150 BANJO DRIVE, CRAWFORDSVILLE, IN 47933
 WEB SITE: WWW.BANJO.CORP.COM
 E-MAIL: BANJOSALES@IDEXCORP.COM

DESCRIPTION
 1 1/4" NPT SIDE LOAD VALVE ASSY

PART NUMBER
 V125SL