

SECTION B-B  
SCALE 1:1

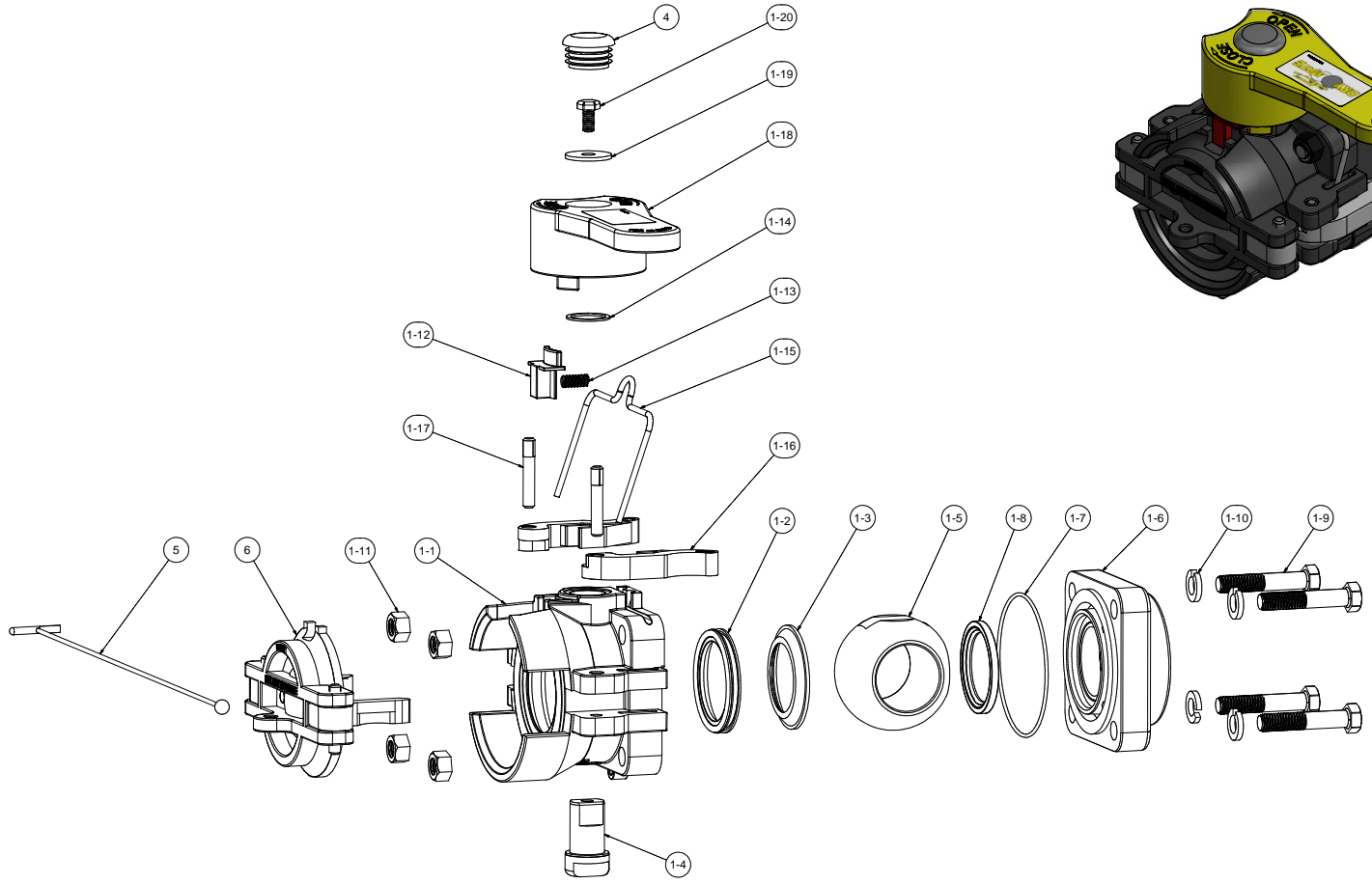

Parts List			
ITEM	QTY	PART NUMBER	DESCRIPTION
1	1	DM200DX	2" POLY FEMALE DRYMATE
1-1	1	DM20254F	2" FEMALE DRYMATE BODY MACHINED
1-2	1	DM20294A	2" DRYMATE SEAL
1-3	1	DB20258	2" DRYMATE TEFLON SEAT
1-4	1	VS20151	VALVE STEM W/ BEARING
1-5	1	DB20255	1-1/2" 2" DRYMATE BALL, MACHINED
1-6	1	DM20256	2" FNPT DRYMATE END PLATE
1-7	1	V21204V	1 1/2" DRYMATE BODY O-RING
1-8	1	V20258A	2" Valve Seat
1-9	4	V20010SS	3/8-16 X 2" HHCS
1-10	4	V20018	3/8" LOCKWASHER
1-11	4	V20019	3/8" HEX NUT
1-12	1	DB20288	LOCK BUTTON
1-13	1	DB20281	Dry Mate Handle Interlock Spring
1-14	1	V20060	VALVE STEM THRUST BEARING
1-15	1	DM20289	2" POLY DRYMATE LOCK YOKE
1-16	2	DM200KX	2" DRYMATE CAM ARM
1-17	2	200P	CAM ARM PIN
1-18	1	DM20153F	2" DM FEMALE SHORT HANDLE
1-19	1	V20021	Handle Washer
1-20	1	V20020	2" handle Bolt
2	1	DB20002	DRY MATE LABEL
3	1	VL1000	100 PSI PRESSURE LABEL VITON SEALS
4	1	V20353C	1 1/8" CAPPLUG
5	1	V20207A	Polyurethane Lanyard
6	1	DM200PL	2" DRYMATE PLUG
7	1	050DECAL	Banjo Logo Decal

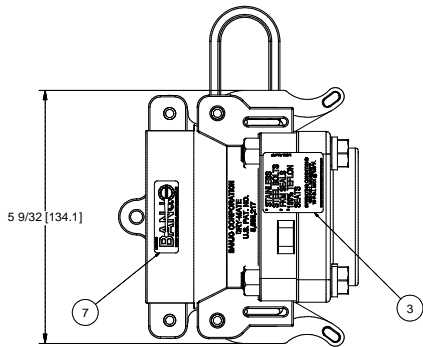
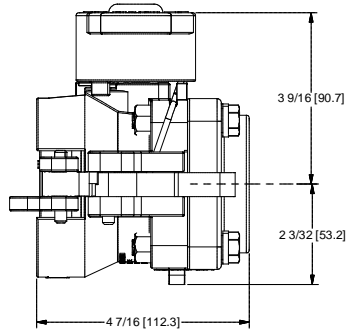