

Parts List			
ITEM	QTY	PART NUMBER	DESCRIPTION
1	1	DM200AX	2" POLY MALE DRYMATE
1-1	1	DM20254	2" MALE DM BODY
1-2	1	DB20290	2" DRYMATE SEAL
1-3	1	DB20258	2" DRYMATE TEFLON SEAT
1-4	1	DB20255	1-1/2" 2" DRYMATE BALL, MACHINED
1-5	1	V20258A	2" Valve Seat
1-6	1	V21204V	1 1/2" DRYMATE BODY O-RING
1-7	1	DB20294	DRYMATE SPACER INSERT
1-8	1	DM20265	2" MALE DRYMATE SPACER O-RING
1-9	1	DM20266	2" FNPT DRYMATE END PLATE
1-10	1	VS20151	VALVE STEM W/ BEARING
1-11	1	V20021	Handle Washer
1-12	1	V20020	2" handle Bolt
1-13	1	V20060	VALVE STEM THRUST BEARING
1-14	1	DB20288	LOCK BUTTON
1-15	1	DB20281	Dry Mate Handle Interlock Spring
1-16	1	DM20153M	2" MALE DM HANDLE
1-17	4	V20010SS	3/8-16 X 2" HHCS
1-18	4	V20018	3/8" LOCKWASHER
1-19	4	V20019	3/8" HEX NUT
1-20	2	DM20300	2" DRYMATE PROFILE INSERT
1-21	2	200P	CAM ARM PIN
2	1	DB20002	DRY MATE LABEL
3	1	050DECAL	Banjo Logo Decal
4	1	VL1000	100 PSI PRESSURE LABEL VITON SEALS
5	1	DM200CAP	2" DRYMATE CAP
6	1	V20207A	Polyurethane Lanyard
7	1	V20353C	1 1/8" CAPPLUG

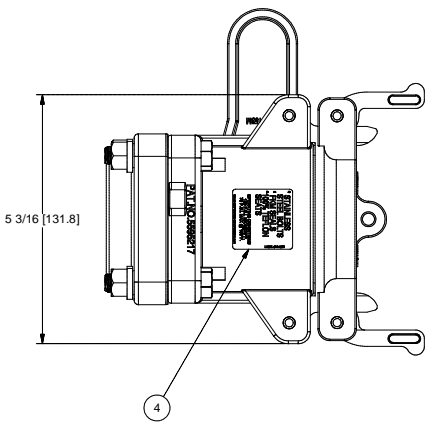
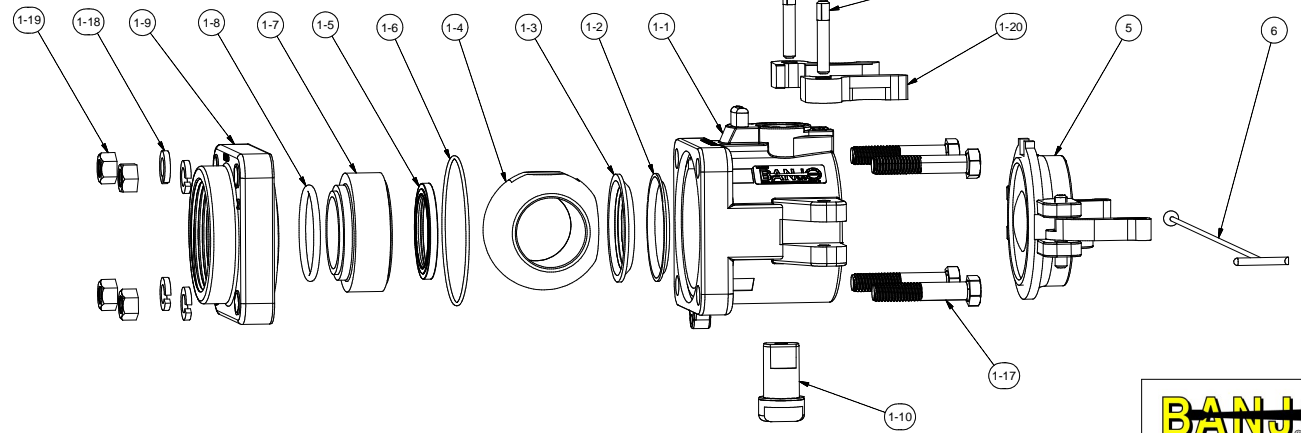
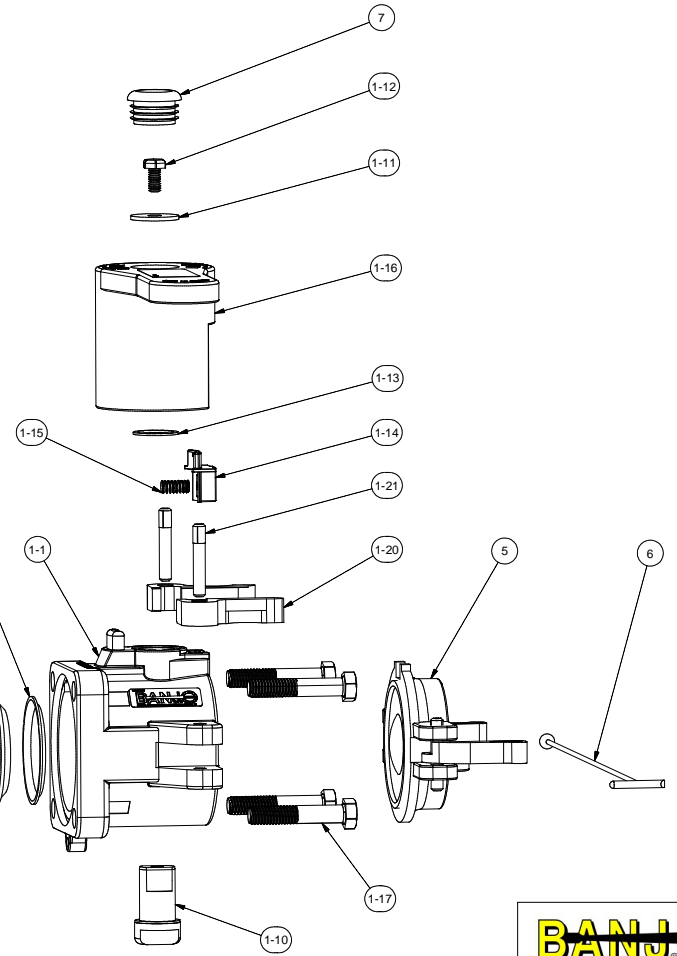
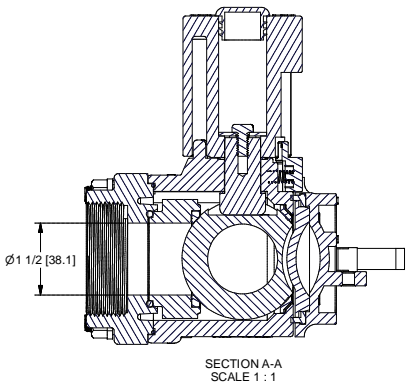
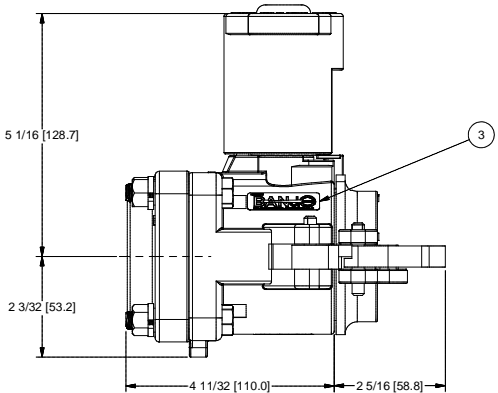

THIS DRAWING AND ALL INFORMATION CONTAINED THEREON ARE THE EXCLUSIVE PROPERTY OF BANJO CORPORATION.

UNLESS SPECIFICALLY NOTED, THIS DRAWING AND ITEMS SHOWN ON THIS DRAWING ARE SUBJECT TO CHANGE AT ANY TIME.

BANJO CORPORATION
 150 BANJO DRIVE, CRAWFORDSVILLE, IN 47933
 WEB SITE: WWW.BANJOCORP.COM
 E-MAIL: SALES1@BANJOCORP.COM

DESCRIPTION:
 2" POLY MALE DRYMATE

PART NUMBER:
 DM200A