

NOTE:
GALLONAGE MARKS MAY BE REMOVED FOR FITTING PLACEMENT AS NEEDED.

***ALL EXTERNAL PIPING MUST BE INDEPENDENTLY SUPPORTED.**
***ONLY BASE FITTINGS TO BE LEFT INSTALLED AT TIME OF SHIPMENT PER SII PROCEDURE.**
***Consult Snyder's Guidelines for Use and Installation prior to delivery.**
 Available on-line at <http://www.snyderindustriestanks.com/Technical>
ALL DIMENSIONS ARE IN INCHES, NOMINAL, & SUBJECT TO CHANGE WITHOUT NOTICE.
ALL DIMENSIONS ON ROTATIONAL MOLDED PARTS ARE SUBJECT TO A \pm 3% TOLERANCE.

DO NOT SCALE	DRAWN BY ET3	DATE 07/30/2013	SNYDER INDUSTRIES, INC. 4700 Fremont Street Lincoln, NE 68504 (402) 467-5221 www.snyder.net	TITLE: ASM TK 550 VCT X 48	REVISION A
© SNYDER INDUSTRIES INC., 2014 <small>ALL DIMENSIONS, DESIGNS, AND INFORMATION ON THIS PRINT MUST BE CONSIDERED PROPRIETARY TO SNYDER INDUSTRIES, INC. AND MAY NOT BE USED, COPIED, OR DISTRIBUTED WITHOUT WRITTEN PERMISSION OF AN OFFICER (OR HIS AGENT) OF THE FIRM.</small>				PART NO. 180000N__01	ENG. ID. D001097

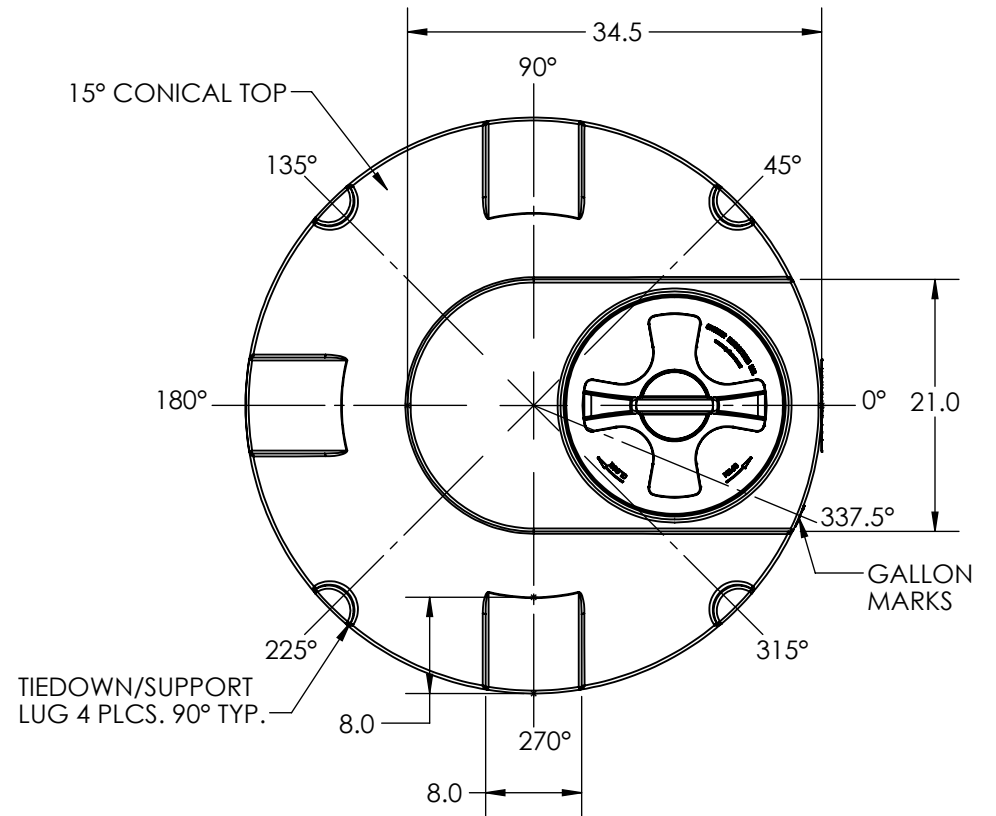
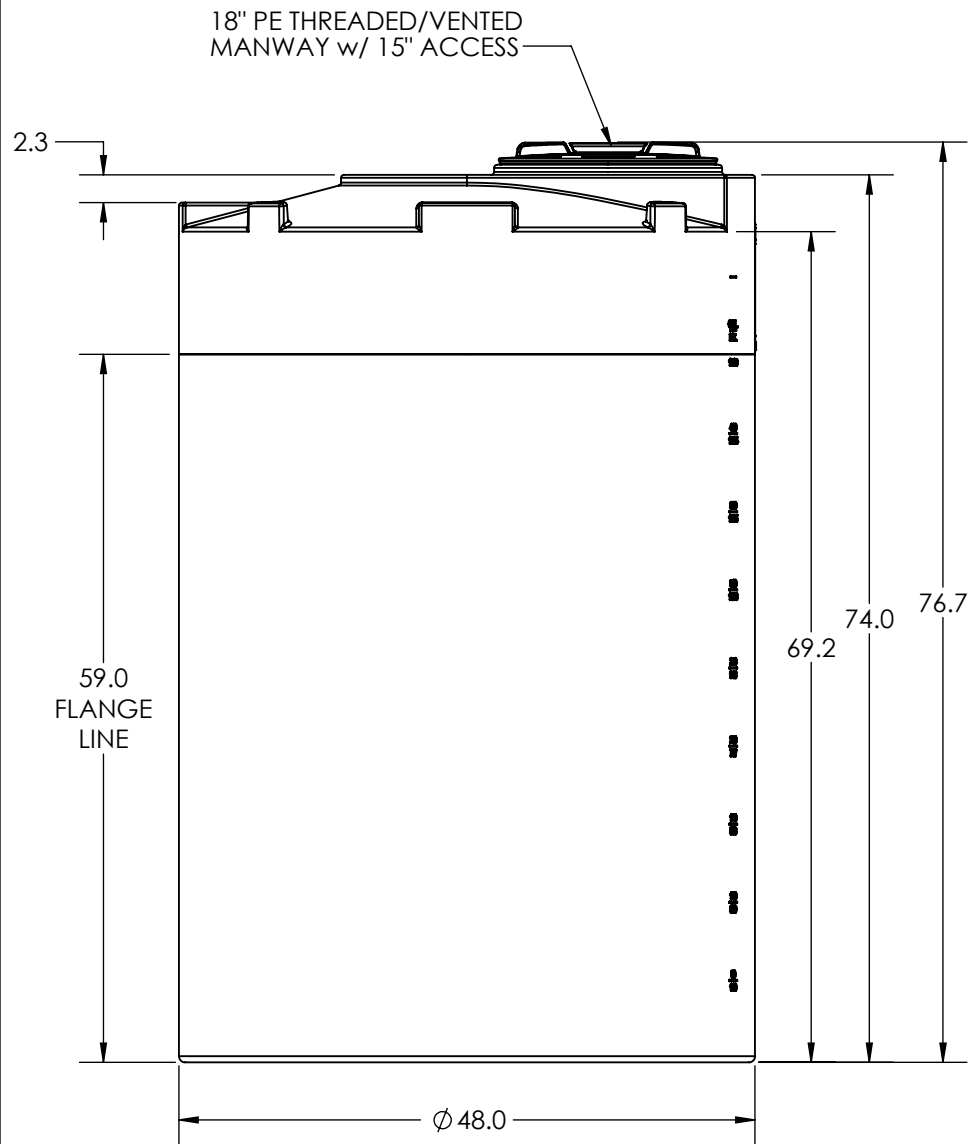

NOTE:
GALLONAGE MARKS MAY BE REMOVED FOR FITTING PLACEMENT AS NEEDED.

*ALL EXTERNAL PIPING MUST BE INDEPENDENTLY SUPPORTED.
 *ONLY BASE FITTINGS TO BE LEFT INSTALLED AT TIME OF SHIPMENT PER SII PROCEDURE.
 *Consult Snyder's Guidelines for Use and Installation prior to delivery.
 Available on-line at www.snyderindustriestanks.com/Technical

ALL DIMENSIONS ARE IN INCHES, NOMINAL, & SUBJECT TO CHANGE WITHOUT NOTICE.
 ALL DIMENSIONS ON ROTATIONAL MOLDED PARTS ARE SUBJECT TO A ± 3% TOLERANCE.

DO NOT SCALE		DRAWN BY	 SNYDER INDUSTRIES, INC. (402) 467-5221 www.snyderindustriestanks.com	TITLE:	ASM TK 550VCT X 48	REVISION
STATUS:		BH		A		
© SNYDER INDUSTRIES INC., 2017				PART NO.	1800500N	SHEET
<small>ALL DIMENSIONS, DESIGNS, AND INFORMATION ON THIS PRINT MUST BE CONSIDERED PROPRIETARY TO SNYDER INDUSTRIES, INC. AND MAY NOT BE USED, COPIED, OR DISTRIBUTED WITHOUT WRITTEN PERMISSION OF AN OFFICER (OR HIS AGENT) OF THE FIRM.</small>			<small>TOLERANCES UNLESS OTHERWISE SPECIFIED: ANGULAR = ±1/2° FRACTIONAL = ±1/16" .X = ±0.1", .XX = ±.03", .XXX = ±.010"</small>	ENG. ID.	D009193	1 OF 1

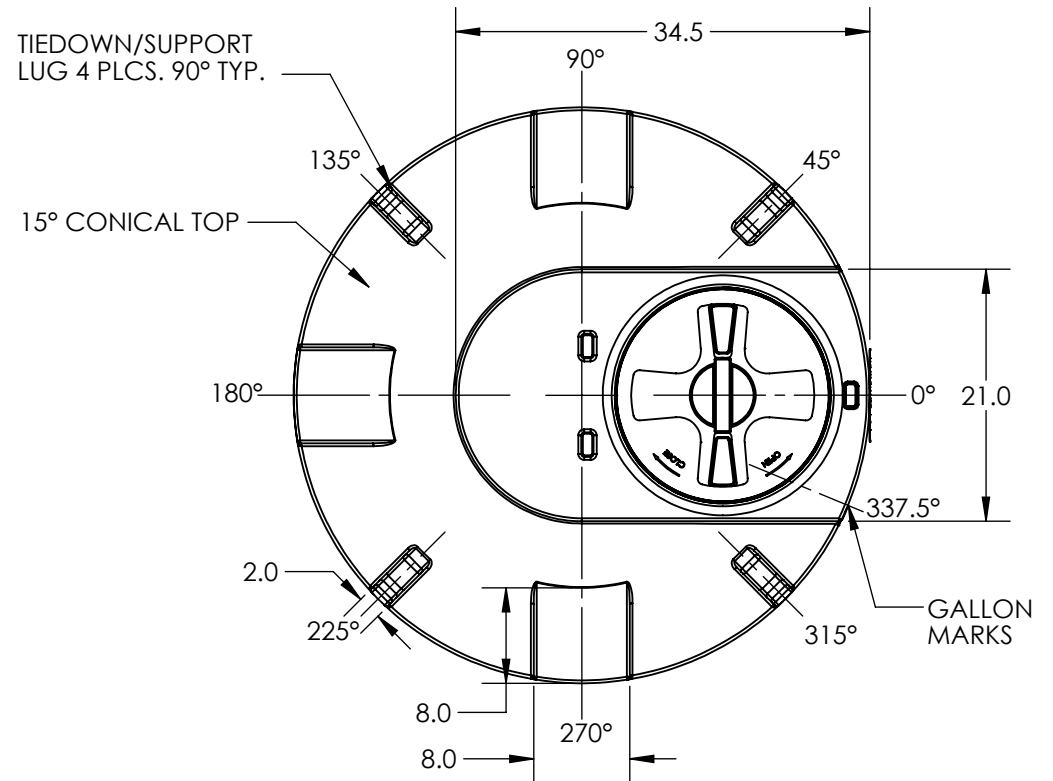
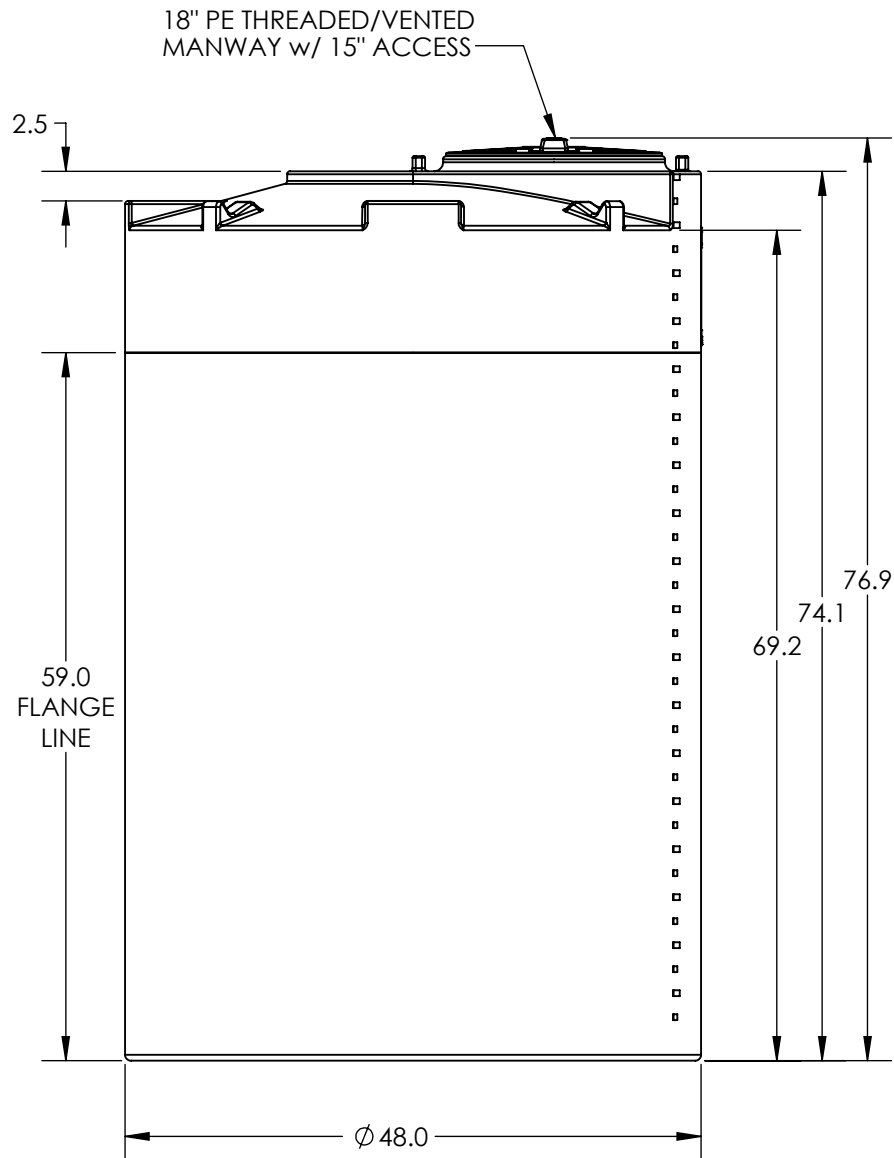

NOTE:
GALLONAGE MARKS MAY BE REMOVED FOR FITTING PLACEMENT AS NEEDED.

***ALL EXTERNAL PIPING MUST BE INDEPENDENTLY SUPPORTED.**
***ONLY BASE FITTINGS TO BE LEFT INSTALLED AT TIME OF SHIPMENT PER SII PROCEDURE.**
***Consult Snyder's Guidelines for Use and Installation prior to delivery.**
 Available on-line at <http://www.snyderindustriestanks.com/Technical>
ALL DIMENSIONS ARE IN INCHES, NOMINAL, & SUBJECT TO CHANGE WITHOUT NOTICE.
ALL DIMENSIONS ON ROTATIONAL MOLDED PARTS ARE SUBJECT TO A ± 3% TOLERANCE.

DO NOT SCALE		DRAWN BY	TITLE:		REVISION
STATUS: Released		ET3	ASM TK 550VCT X 48		A
© SNYDER INDUSTRIES INC., 2015			PART NO.		SHEET
ALL DIMENSIONS, DESIGNS, AND INFORMATION ON THIS PRINT MUST BE CONSIDERED PROPRIETARY TO SNYDER INDUSTRIES, INC. AND MAY NOT BE USED, COPIED, OR DISTRIBUTED WITHOUT WRITTEN PERMISSION OF AN OFFICER (OR HIS AGENT) OF THE FIRM.			1800200N		1 OF 1
www.snyderinet.com			ENG. ID.		
			D001099		